



# KMA Genuine Approved Accessories (Preparation) Pg. 1

Vehicle Model	Borrego	Accessory	Expansion Light Kit
Model Year	2009	Difficulty	B
KMA Part No.	UH090 AY311		

- Preparation
- Disassembly
- Accessory Installation
- Reassembly Sheet
- Function Check
- Visual Check
- Trouble Shooting

Note: Difficulty stated above reflects the minimum level of expertise required to install the accessory  
 ( A ) Customer ( B ) Dealer Technician ( C ) Master Technician

### Instructional Symbols / Definitions

 Denotes warnings that may lead to serious physical injury or vehicle damage.	 Denotes quality processes to be checked prior to moving to the next step.	Denotes safety equipment required to be used such as a mask, goggles, rubber gloves, and hearing protection.
 Denotes cautions to be taken to avoid physical injury or electronic component damage.	 Denotes specific tools that are necessary to complete the step.	 Mask
 Denotes cautions to be taken to avoid vehicle and component damage.	 Denotes instructional steps necessary to complete the process.	 Goggles
		 Rubber
		 Hearing Protection

### Basic Required Hand Tools

Philips Head Screw Driver	Panel Removal Tool (Panel Safe)	Ratchet Wrench	Pick Tool
Socket (10 mm)	Drill	Step Drill Bit 3/4"	Drill Bit 1/8" / 5/16"
Scribe or Center Punch			

### Specialty Required Tools

### Notes to the Installer

Read the entire installation pamphlet prior to beginning the installation of the accessory.

Ensure that the vehicle is properly protected in the area that the accessory is to be installed.

To prevent vehicle damage, never place tools on top of painted surfaces, seats, dash pad, console or floor carpet / mat.

Always wear appropriate safety gear to include gloves and eye protection when required.

Prior to disconnecting negative lead to the battery, note on the inspection page the AM/FM and satellite set frequencies.

# KMA Genuine Approved Accessories (Preparation)

## Kit Overview

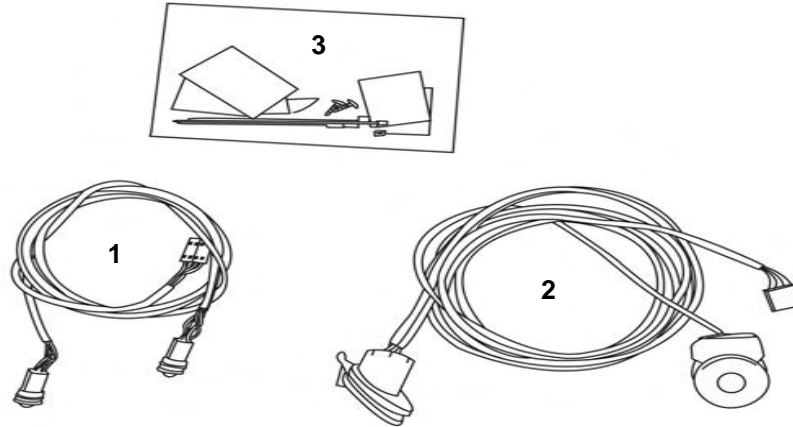

No.	Qty.	Description	No.	Qty.	Description	No.	Qty.	Description
1	1	Front Utility Tray Harness						
2	1	Rear Foot Well Light Harness						
3	1	Hardware Kit						

## Hardware Overview

<b>A</b>								
1	Cup Holder Lens Kit							
<b>B</b>								
11	4" Wire ties							
<b>C</b>								
6	Foam Pad							
							<b>Hardware Kit Total</b>	
								<b>18</b>

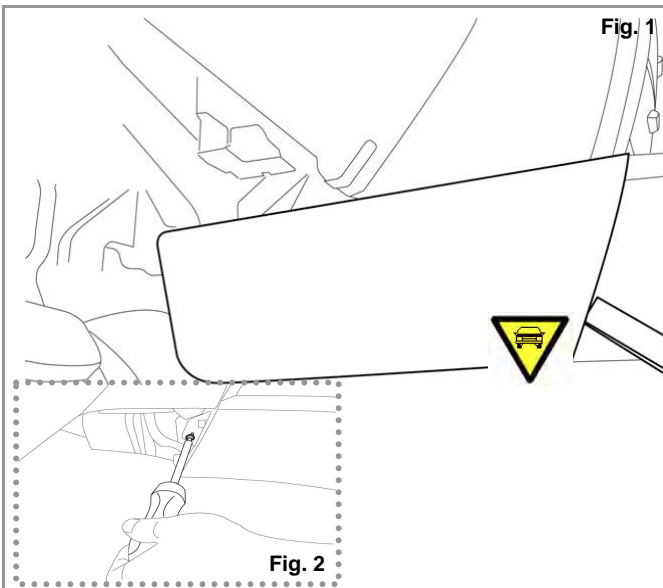

	Panel Removal Tool, Phillips Screw Driver	1
<b>NOTE</b>	Using a panel removal tool, remove the passenger side center console forward trim panel as shown in figure 1. - Using the Phillips screwdriver remove the fastener behind the panel as shown in figure 2	
		Do not mar panel when removing

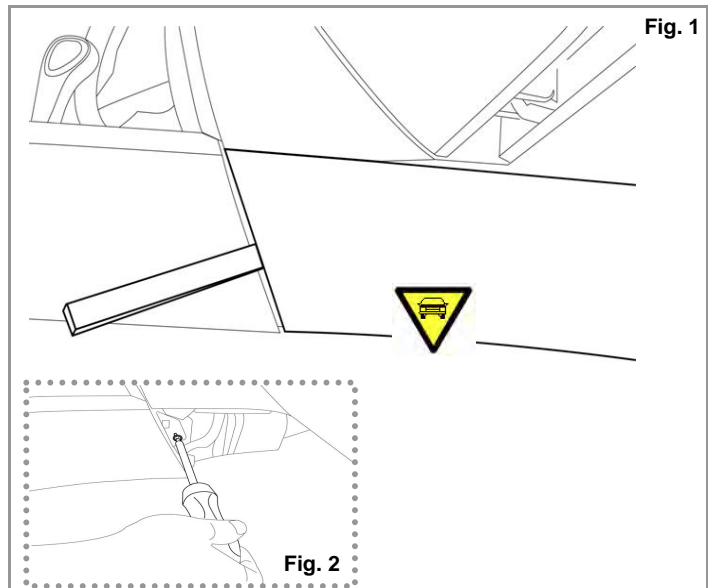

	Panel Removal Tool, Phillips Screw Driver	2
<b>NOTE</b>	Using a panel removal tool, remove the passenger side center console forward trim panel as shown in figure 1. - Using the Phillips screwdriver remove the fastener behind the panel as shown in figure 2.	
		Do not mar panel when removing

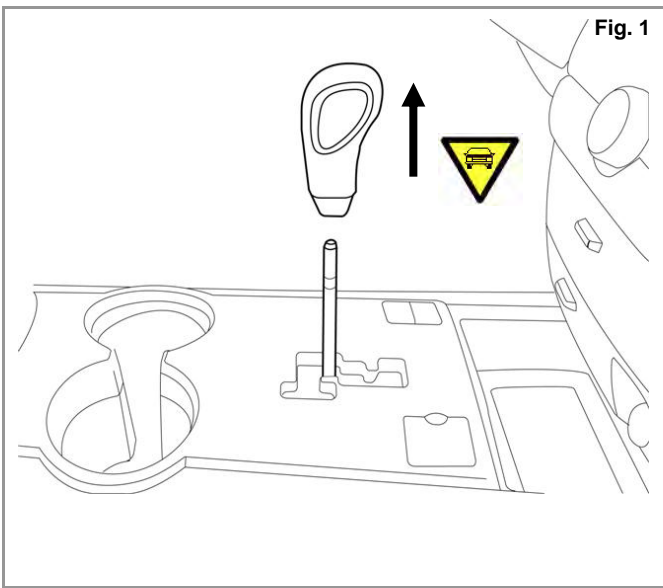

	None	3
<b>NOTE</b>	Remove the handle by applying upward pressure as shown in figure 1. - Place the shift knob in a dry clean area.	
		Be careful not to hit the rear view mirror when performing this step.

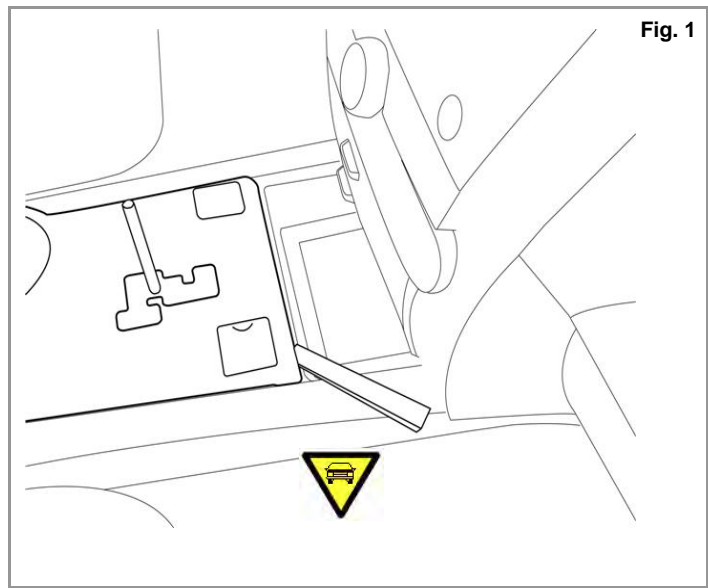

	Panel Removal Tool	4
<b>NOTE</b>	Using the panel removal tool, pry the forward edge of the shifter bezel upward as shown in figure 1.	
		Be careful not to mar the shifter bezel when performing this step

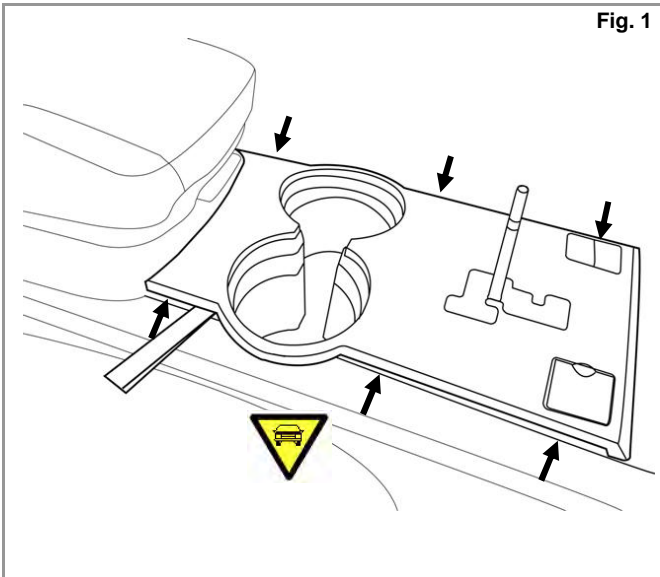

Fig. 1

	Panel Removal Tool	5
<b>NOTE</b>	Dislodge the bezel using the panel removal tool. Dislodge the bezel starting from the front and moving rearward as shown in figure 1.	
	Be careful not to bend the shifter bezel when performing this step.	

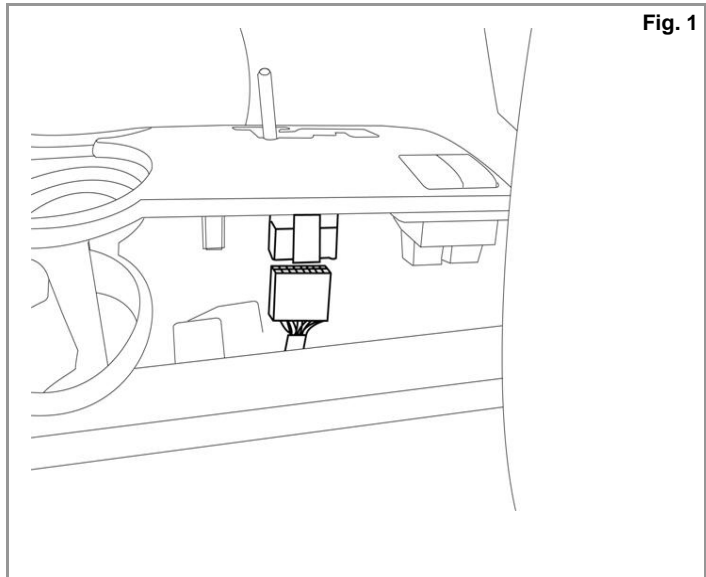

Fig. 1

	None	6
<b>NOTE</b>	Remove the switches affixed to the shifter bezel. Once disconnected, remove the bezel as shown in figure 1 and place into a clean dry area.	
	Hold connectors when disconnecting. Do not hold the wires since this may damage the harness.	

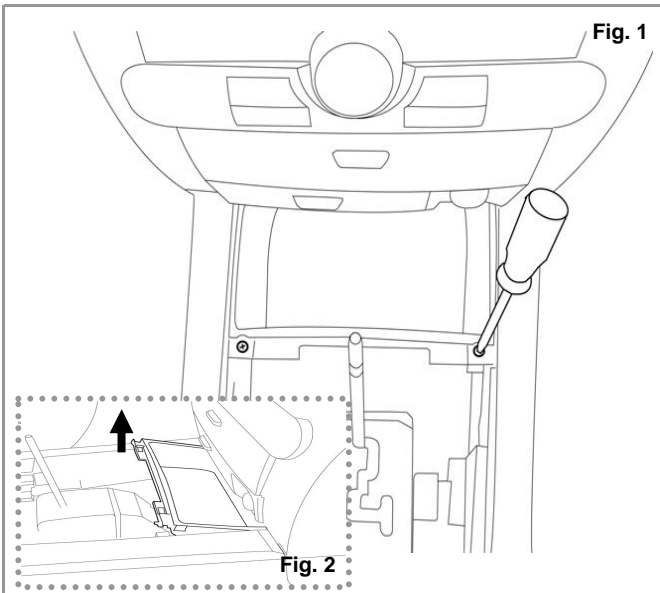

Fig. 1

	Phillips Screw Driver	7
<b>NOTE</b>	Using a Phillips screw driver remove the two screws securing the front tray to the center console as shown in figure 1.	
	<ul style="list-style-type: none"> <li>- Apply upward pressure to dislodge the front tray as shown in figure 2</li> <li>- Place into a clean dry area</li> </ul>	
	Be careful not to mar the front tray when removing the screws.	

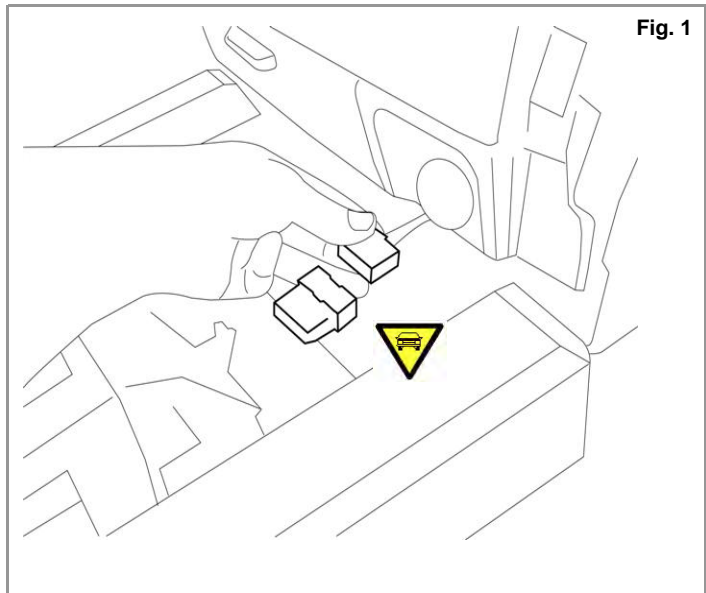

Fig. 1

	None	8
<b>NOTE</b>	Disconnect the electrical connector(s) forward of the shifter as shown in figure 1.	
	Only hold the connectors when removing. This will prevent any damage to the wires.	

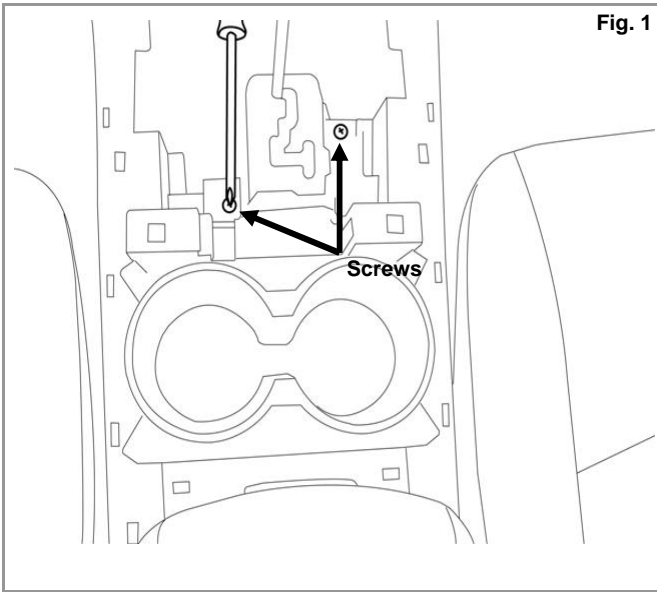

Fig. 1

	Phillips Screw Driver	9
<b>NOTE</b>	Remove the four screws shown above and place in a safe area as shown in figure 1.	
	Be careful to not strip the screw heads performing this step.	

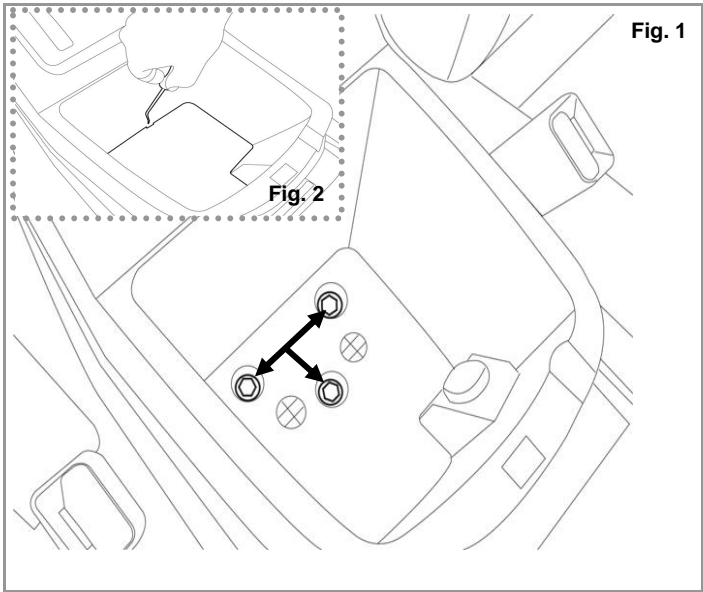

Fig. 1

	Ratchet, Eight Inch Extension, 10mm Socket, Pick Tool	10
<b>NOTE</b>	Remove the cargo liner felt using the pick tool. Place in a clean dry area as shown in figure 2, - Using the ratchet, extension and 10mm socket, remove the three bolts as shown in figure 1. - Place bolts in a safe area.	
	Be careful not to scratch the container wall with the pick tool when removing the felt liner.	

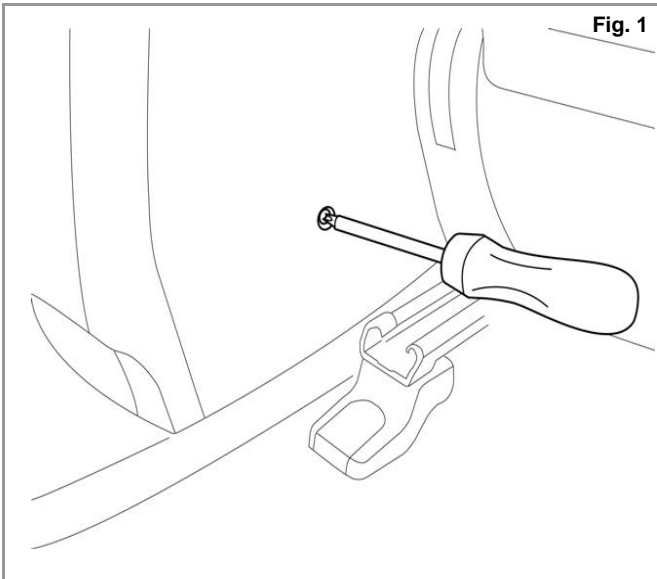

Fig. 1

	Phillips Screw Driver	11
<b>NOTE</b>	Move the drivers and passenger seat to the most forward position. - Remove the screw from the aft end of the center console on the drivers and passenger side as shown in figure 1.	
	Be careful not to mar the center console bezel when removing the screws.	

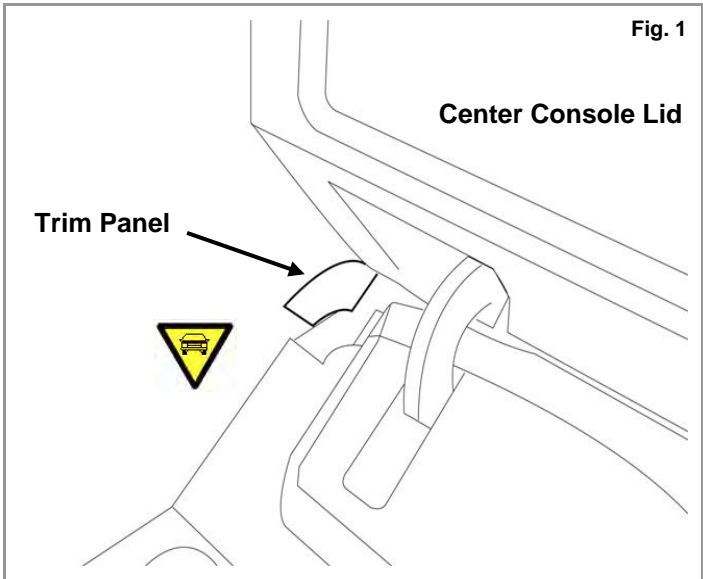
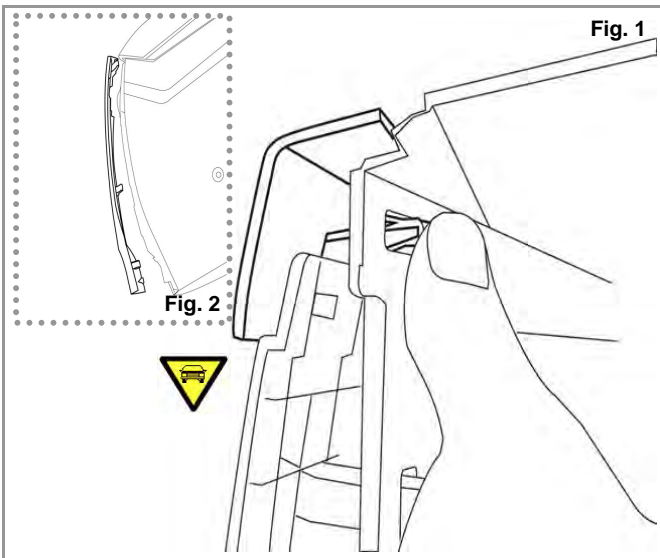
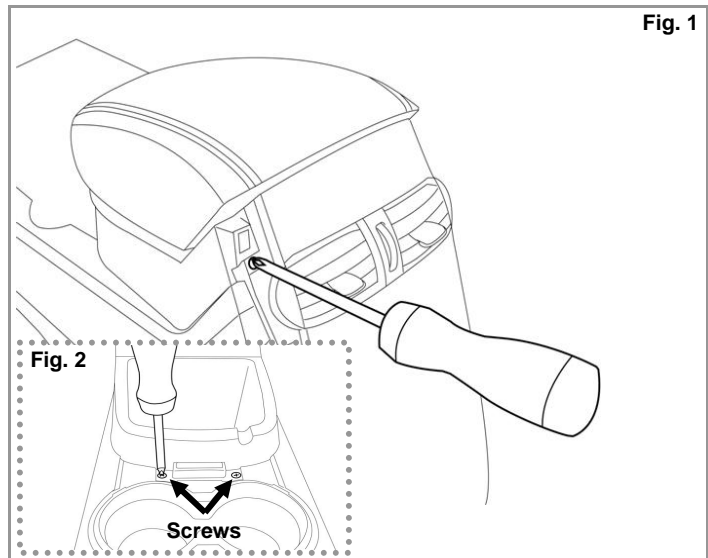

Fig. 1

	None	12
<b>NOTE</b>	Gently press rearward on the trim panel until it dislodges from the center console as shown in figure 1.	
	Be careful not to damage the rear console trim panel when dislodging.	



	None	<b>13</b>
<b>NOTE</b>	Dislodge the trim panel as shown. Be careful to not damage trim panel as shown in figures 1 and 2.	
	Remove the panels and place them into a clean dry area.	



	Phillips Screw Driver	<b>14</b>
<b>NOTE</b>	Remove the two upper screws on the center console rear panel as shown in figure 1.	
	<ul style="list-style-type: none"> <li>- Remove the two screws just aft of the cup holders as shown in figure 2.</li> <li>- Place the screws in a safe area.</li> </ul>	
Be careful to not strip the screws when removing them from the center console.		

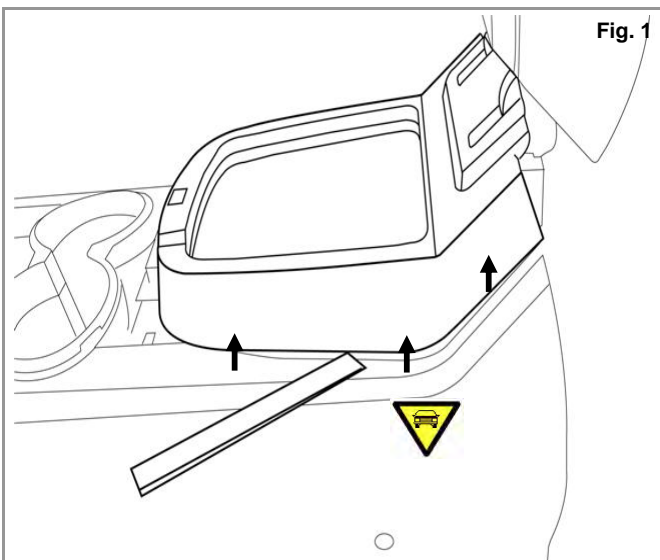

	Panel Removal Tool	<b>15</b>
<b>NOTE</b>	Carefully remove the center console bin bezel from the center console as shown in figure 1.	
	Be especially careful when removing the trim component to prevent damage to the bezel. Clips damage easily	

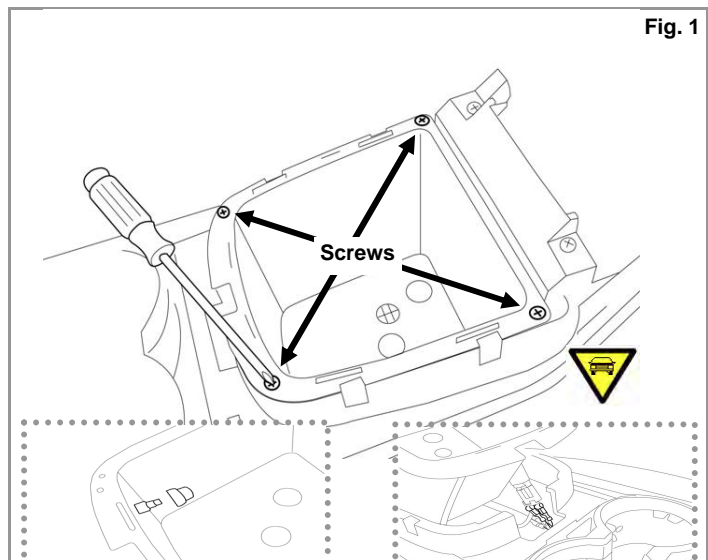

	Phillips Screw Driver	<b>16</b>
<b>NOTE</b>	Remove the four screws from the top of the center console bin as shown in figure 1.	
	<ul style="list-style-type: none"> <li>- Remove the button cover as shown in figure 2.</li> <li>- Lift the center console bin and disconnect the cigarette lighter connector from the bin as shown in figure 3.</li> <li>- Place the bin in a clean dry area.</li> </ul>	
Be careful not to mar the bin when removing.		



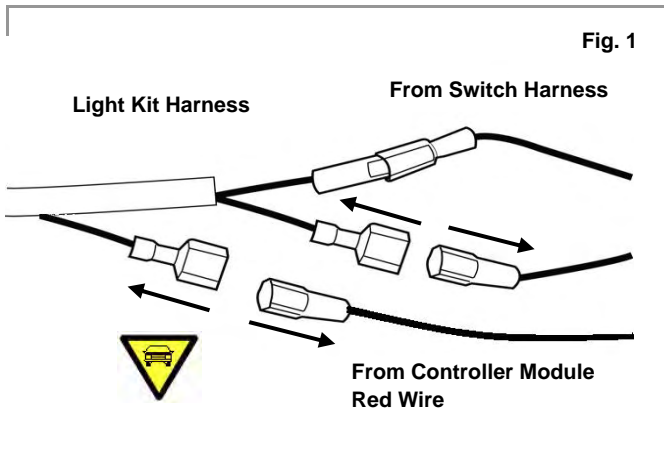

(Picture of harness removed from vehicle for clarity)		
	None	17
<b>NOTE</b>	Disconnect connections as shown in Figure 1 above. -Detach the light kit harness 3/16" quick disconnects from 3/16" quick disconnects on the switch harness. Detach the light kit harness 1/4" quick disconnect (WHITE wire) from controller module 1/4" quick disconnect (RED wire).	

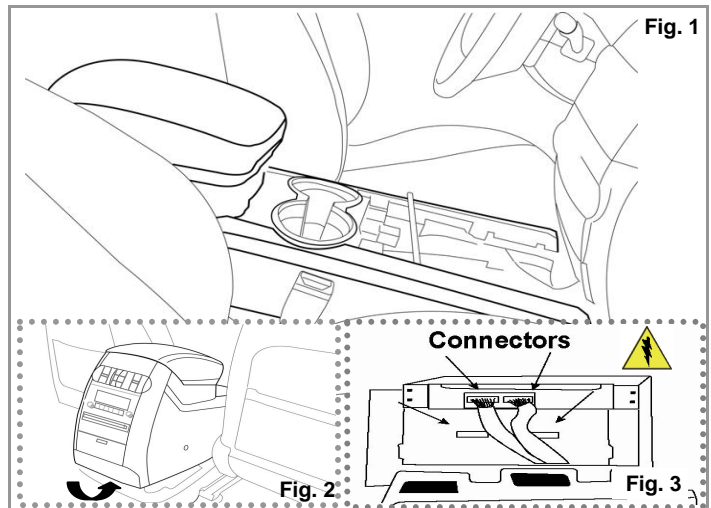

	None	18
<b>NOTE</b>	Tilt the rear of the center console upward and lift the console out of the vehicle as shown in figures 1. - If the vehicle is equipped with Rear Seat Entertainment (RSE) lift the rear of the console and disconnect the four connectors as shown in figures 2 and 3.	
	Ensure the console does not get scratched when performing the next set of steps.	

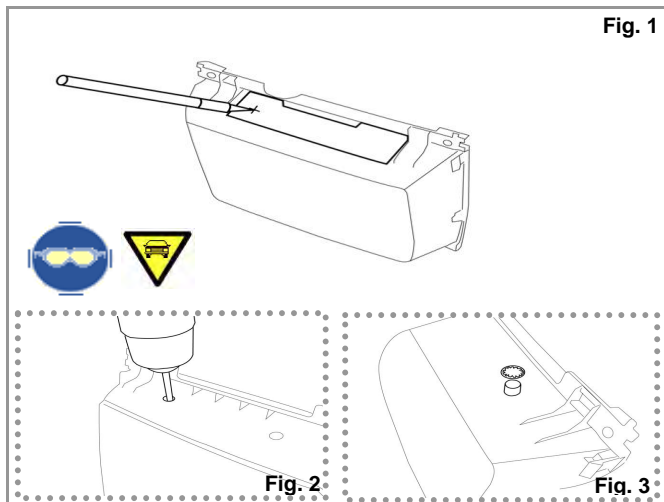

	Center Punch, Drill, 1/8 inch Drill, 5/16 inch Drill	19
<b>NOTE</b>	Using the provided template locate and center punch or scribe the two locations on the forward tray as shown in figure 1. - Drill a 1/8 inch pilot hole into the two punched areas. Using a 5/16 inch drill open the hole to fit the lens as shown in figure 2. - Insert the lens into the forward tray and place a lock washer over the threaded end as shown in figure 3. - Screw the housing with two wires to the drivers side of the forward tray. - Next screw the LED housing with the single wire to the passenger side of the forward tray.	
	Ensure that the LED fixtures are tight and that the wires are not twisted when completing this step. Do not oversize the holes when drilling tray.	

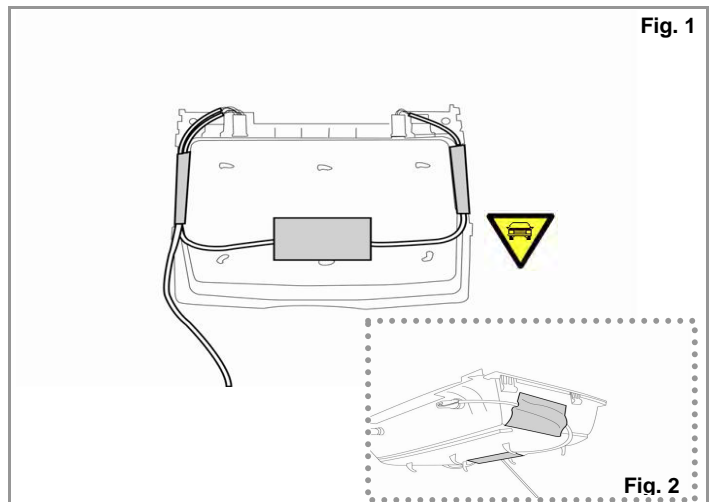

	None	20
<b>NOTE</b>	Route forward tray harness as shown in figure 1. - Run wire from passenger side of tray along the side and across bottom of tray assembly. Then go along drivers side of tray toward housing mounted on drivers side as shown in figure 2. - Attach harness to tray with 3 foam pads and set aside in a clean dry area.	
	It is important to route the wires as described to avoid interference with the shifter when moved to the park position.	

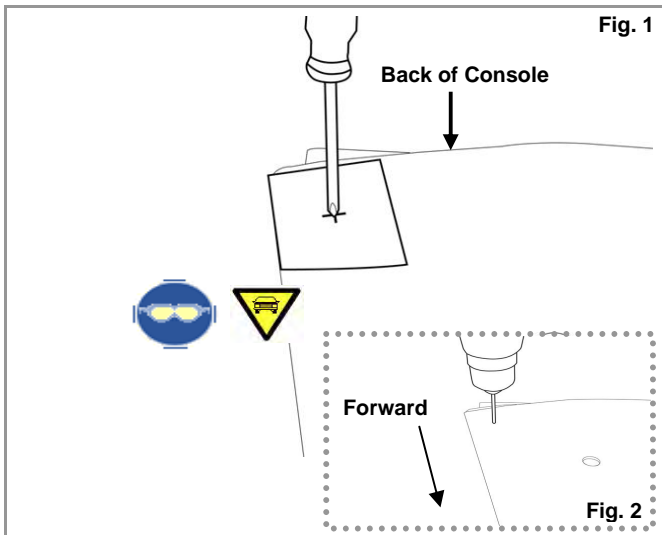

	Center Punch, Drill, 1/8 Inch Drill	<b>21</b>
<b>NOTE</b>	Use rear foot well drill template and a scribe. Mark the left and right side of center console for light housing installation as shown in figure 1. - Use the mirror image of the template for the passenger side of the console. - Drill a 1/8 inch pilot hole into the center console bezel at the scribed mark on both the left and right side as shown in figure 2.	
	Be careful not to mar the center console or have a drill bit chip when performing this step.	

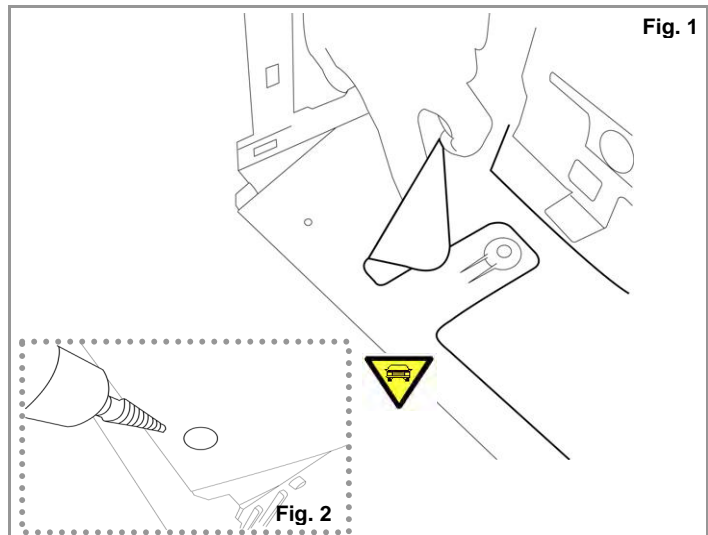

	Drill, 3/4 Inch Drill	<b>22</b>
<b>NOTE</b>	On the inside of the center console, gently peel the liner back approximately one inch as shown in figure 1. - Use a step drill and drill a 3/4 inch hole in both the left and right side of center console as shown in figure 2.	
	Be careful not to mar the center console when performing this step.	

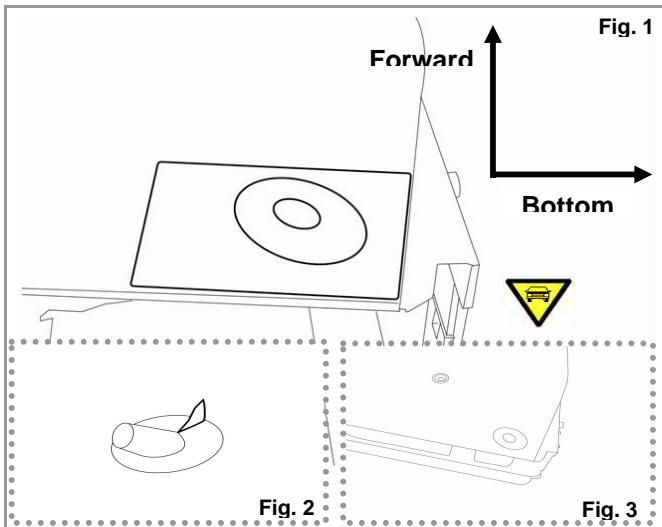

	None	<b>23</b>
<b>NOTE</b>	Use the rear area lighting alignment template and install the exterior light bezel assembly. The light channel in the housing should point toward the rear of console at a slight downward angle as shown in figures 1 and 3. - Use mirror image of template for passenger side of console. - Remove the liner as shown and install by applying even pressure to the fixture against the center console as shown in figure 2.	
	Confirm that the light fixture appears as shown in the image above (lower right corner).	

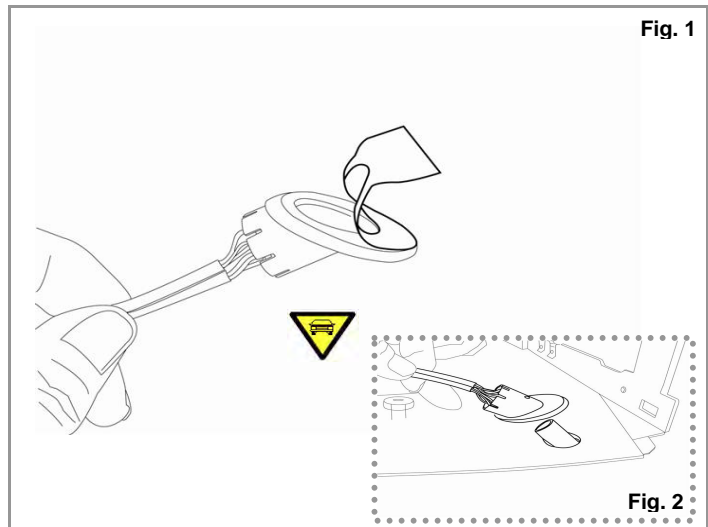

	None	<b>24</b>
<b>NOTE</b>	Remove the tape liner from the light fixture housing as shown in figure 1. Install the housing with two wire onto the passenger side lens fixture as shown in figure 2. - From the interior of the center console, slide the LED and fixture over the top of the previously installed outer fixture as shown in figure 2. Repeat this step for the single wire on the drivers side of the center console.	
	Ensure a good bond exists between the LED and fixture to the center console.	



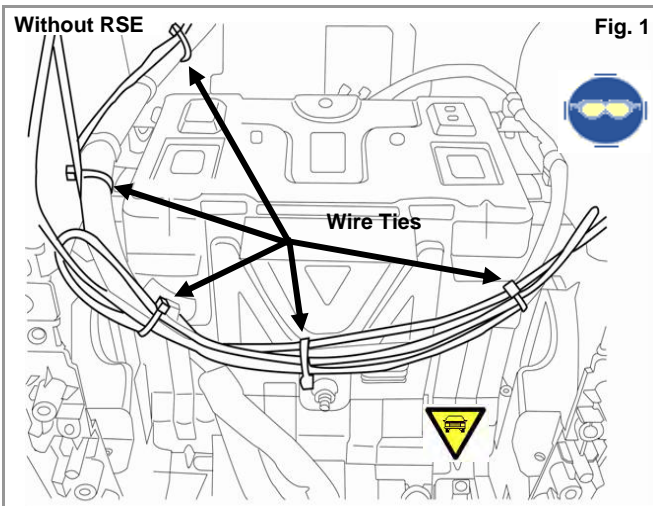

Fig. 1

Diagonal Cutters 25a

**N  
O  
T  
E** Bundle the extra wire between light fixture housing. Attach the bundle of wire with three 4" wire tie to console harness as shown in figure 1.

Be careful to not nick the harness when cutting the excess wire ties.

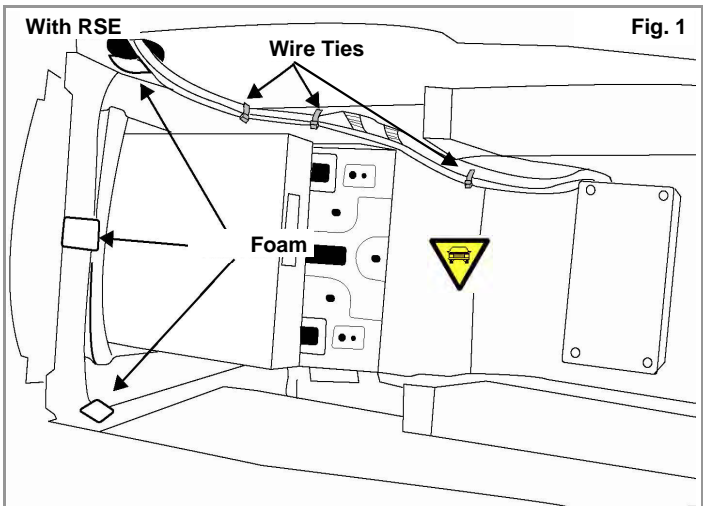

Fig. 1

Diagonal Cutters 25b

**N  
O  
T  
E** Run the light housing harness assembly to the console harness and secure to console using three foam pads and three wire ties as shown in figure 1.

Be careful to not nick the harness when cutting the excess wire ties.

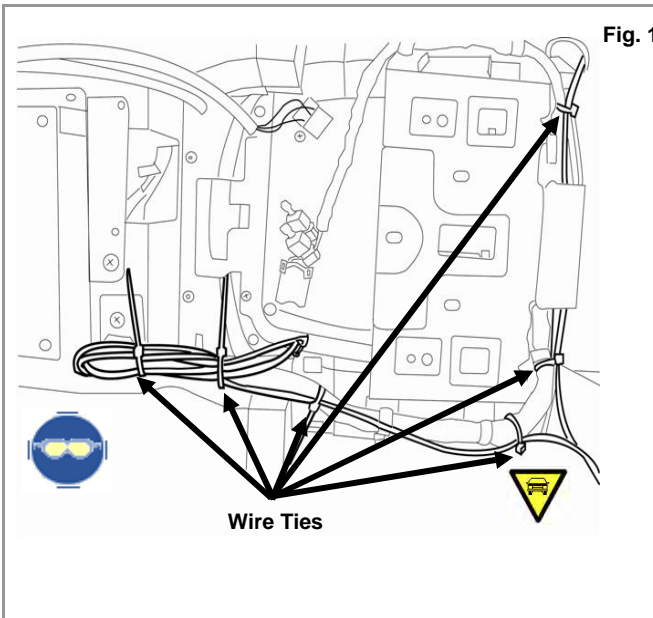

Fig. 1

Diagonal Cutters 26

**N  
O  
T  
E** Run the light housing harness assembly to the console harness and secure with three wire ties as shown in figure 1.

**N  
O  
T  
E**

Be careful to not nick the harness when cutting the excess wire ties.

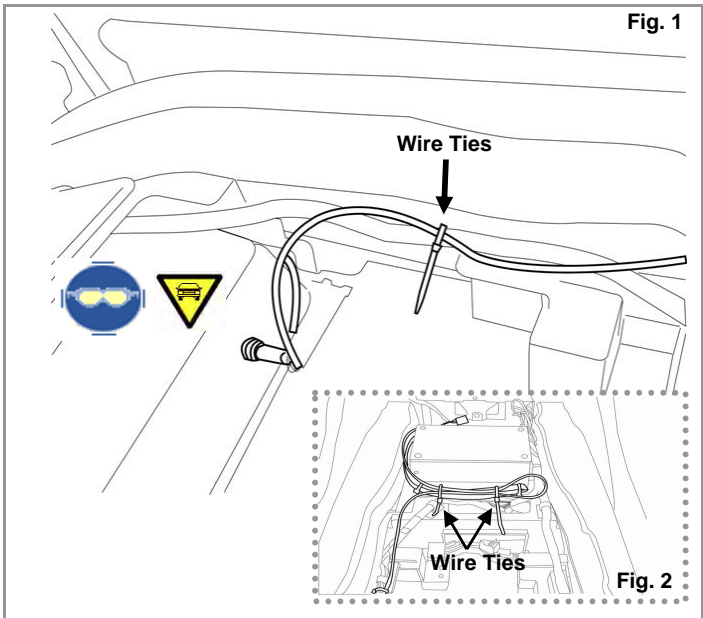
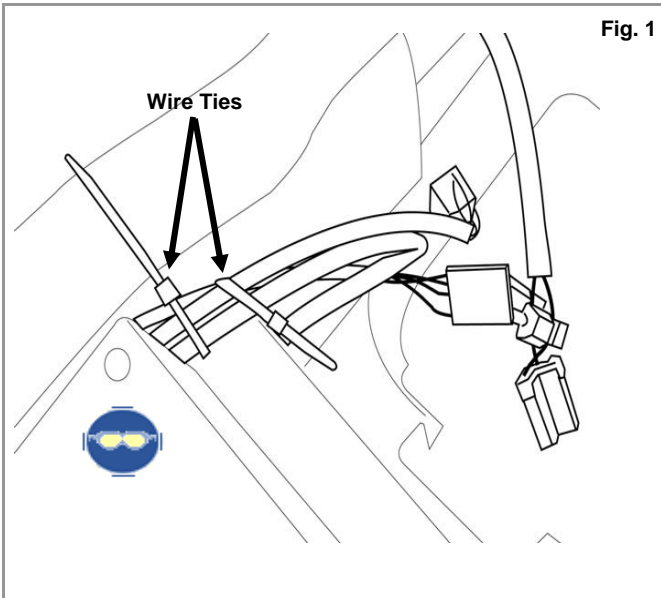



Fig. 1

Diagonal Cutters 27

**N  
O  
T  
E** Install the forward tray with the lights already installed into its position on the center console as shown in figure 1.  
- Attach the light harness to console harness. Leave approximately 6" of distance before attaching with a 4" wire tie as shown in figure 1.  
- Bundle extra forward tray lighting harness behind controller box. Attach to cup lighting harness already installed. Attach the harness with two 4" wire ties as shown in figure 2.

Be careful to not nick the harness when cutting the excess wire ties.



	Diagonal Cutters	28
<b>N O T E</b>	Run harness along the side of controller box with cup lighting harness as shown in figure 1. - Attach to cup lighting four pin connector with the four pin connector of the forward tray harness.	
	Be careful to not nick the harness when cutting the excess wire ties.	

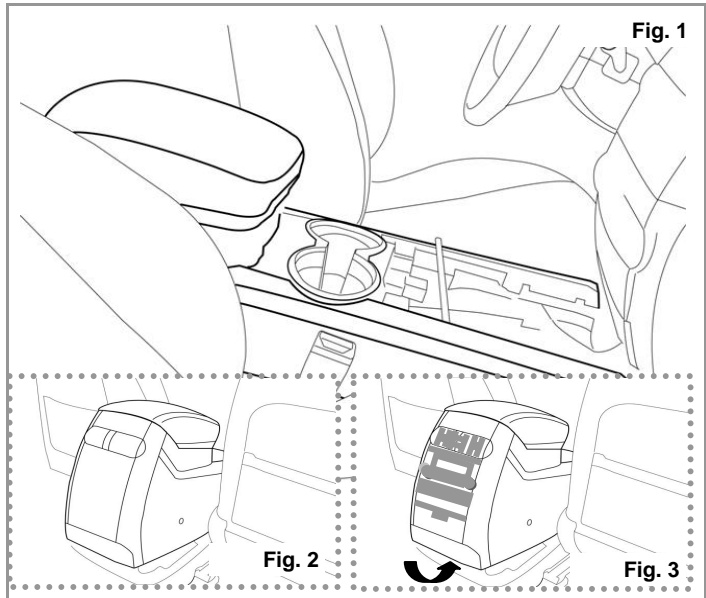

	None	29
<b>N O T E</b>	Carefully reinstall the center console into the vehicle. - Ensure that the wire harness does not get pinched between the rear brace and the frame of the center console as shown in figures 1 and 2. If equipped with RSE, carefully lift rear of console and reconnect the four connectors as shown in figure 3. Do not secure the center console to the vehicle at this point.	

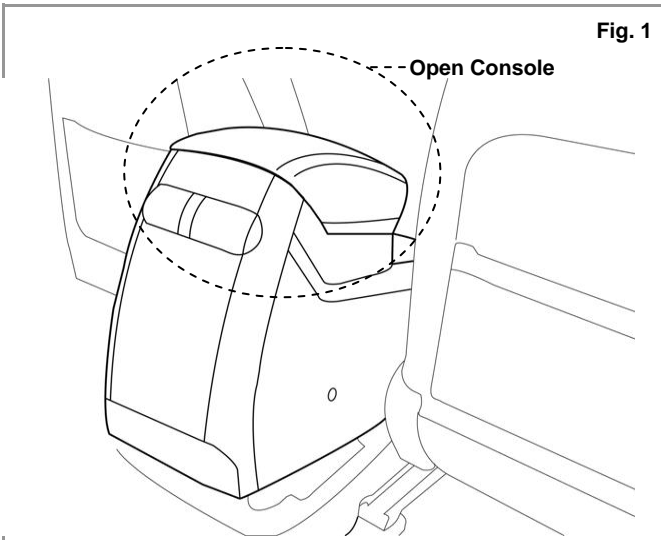

	None	30
<b>N O T E</b>	Carefully lower the center console into the vehicle. - Ensure that the wire harness does not get pinched between the rear brace and the frame of the center console as shown in figures 1.	
	Do not secure the center console to the vehicle at this point.	

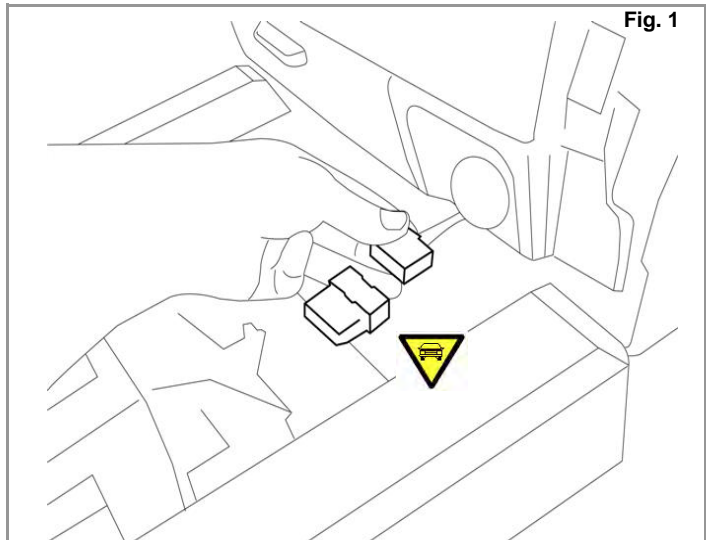



	None	31
<b>N O T E</b>	Reconnect the center console connectors to the vehicle harness just forward of the shifter as shown in figure 1.	
		Ensure that a positive connection between the two connectors is made when performing this step.

Fig. 1

**Controller Board Removed for Clarity**



**Black Color Connector**

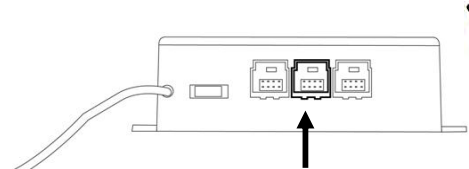

	None	<b>32</b>
<b>NOTE</b>	Attach the LED harness connector (black) to the matching black connector on controller board as shown in figure 1. (Picture of control box removed from vehicle for clarity) - Attach 5 pin connector from rear console lights to 5 pin connector wire tied to LED harness.	
	Ensure that the connector has a positive connection to the module prior to moving to the next step	

Fig. 1



**Natural Color Connector**



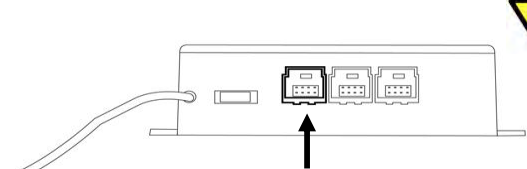



	None	<b>33</b>
<b>NOTE</b>	Attach the natural switch harness connector to the matching natural connector on controller board as shown in figure 1.	
	Ensure that the connector has a positive connection to the module prior to moving to the next step	

Fig. 1

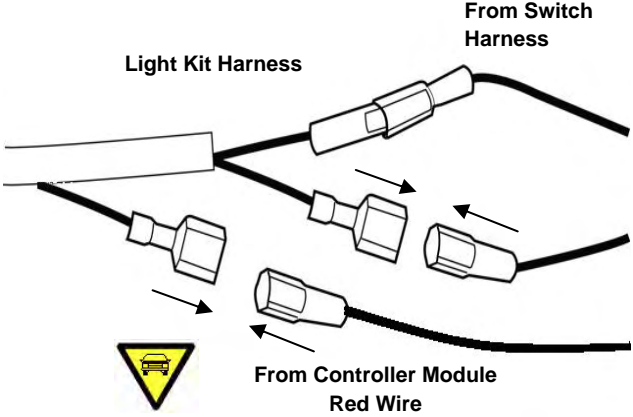

		<b>34</b>
<b>NOTE</b>	Make connections as shown in Figure 1 above. Attach the light kit harness 3/16" quick disconnects to 3/16" quick disconnects on the switch harness. Attach the light kit harness 1/4" quick disconnect (WHITE wire) to controller module 1/4" quick disconnect (RED wire).	
	Ensure that the connectors are fully inserted into one another.	

Turn to the function check section of the manual and follow the steps outlined to confirm that the mood lighting system functions. Do not proceed with the remainder of the steps until the function test is completed.

	None	<b>35</b>
<b>NOTE</b>		

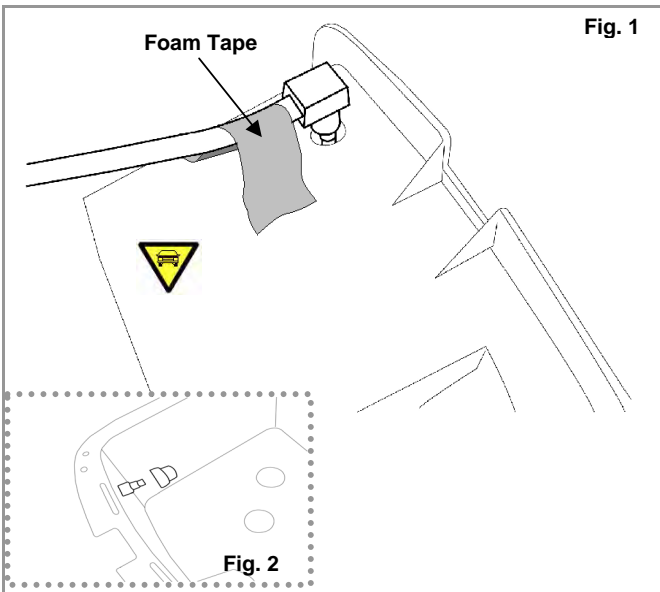

	None	<b>36</b>
<b>N O T E</b>	Install the button harness switch through the center console bin as shown in figure 1. - Secure using the rubber boot as shown in figure 2. - Secure harness with a single piece of foam tape. - Perform wire management of all harnesses to ensure that they do not interfere with the parking brake mechanism or rest against SRS module on floorpan.	
	Do not over tighten the rubber boot when securing.	

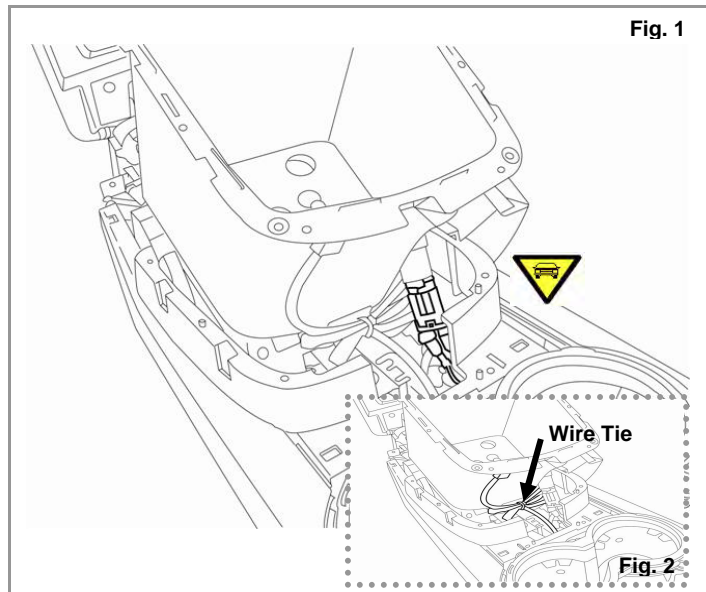

	None	<b>37</b>
<b>N O T E</b>	Reconnect power plug to center bin as shown in figure 1. - Bundle the excess harness as shown in figure 2.	
	Ensure a positive connection is made when performing this step.	

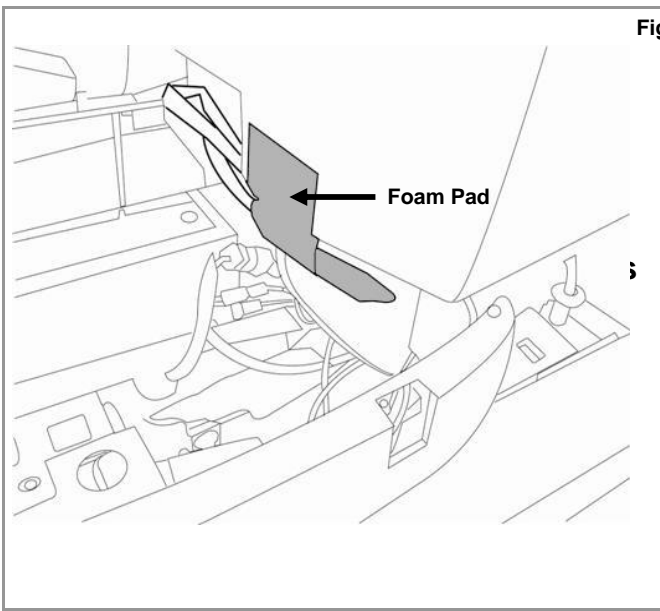

	None	<b>38</b>
<b>N O T E</b>	Secure switch harness bundle to center console with foam pads as shown in figure 1.	
	Ensure the harness is secured to the bin before proceeding to the next step.	

**Re-install all the remaining components and fasteners as described in the reassemble section.**





<b>N O T E</b>		

## Reassembly Sheet ( Expansion Kit )











	Item in Question		Visual Review
	Reinstall the center bin and secure using the four screws.	Instruction Ref. Pg. 6 Step 16 Fig. 1	Bin will be flush to center console after installation without any gaps. Ensure the switch harness does not get pinched.
	Reinstall the center console bin bezel by aligning the clips and lower then lock into position	Instruction Ref. Pg. 6 Step 15 Fig 1	Ensure the console is completely flush paying attention to the area around the bulster hinge.
	Reinstall the two original screws removed from the center console bin bezel.	Instruction Ref. Pg. 6 Step 14 Fig. 2	Do not over torque the screws.
	Reinstall the three bolts removed in the center bin that hold the center console.	Instruction Ref. Pg. 5 Step 10 Fig. 1	Do not over torque the three bolts.
	Reinstall the center console felt liner into the center console.	Instruction Ref. Pg. 5 Step 10 Fig. 2	Fits flat in the bin
	Reinstall the two screws used to secure the center console to the shifter.	Instruction Ref. Pg. 5 Step 9 Fig. 1	Do not over torque the screws.
	Reinstall the forward Tray locking it into position and using the two original screws removed	Instruction Ref. Pg. 4 Step 7 Fig. 1	Do not over torque the screws.
	Reinstall the connectors to the shifter bezel and reinstall the bezel onto the center console.	Instruction Ref. Pg. 4 Step 6 Fig. 1	Ensure that all the clips are locked down and the bezel is completely seated onto the center console.
	Orient the shift knob over the shift post and lock by pressing down firmly.	Instruction Ref. Pg. 3 Step 3 Fig. 1	Ensure the shift knob is firmly seated.
	Reinstall the original screw onto the side of the center console forward end on the passenger side of the vehicle.	Instruction Ref. Pg. 3 Step 2 Fig. 2	Do not over torque the screw.
	Reinstall the passenger footwell inner kick panel. Ensure the panel locks onto the forward clip. Lock panel to forward end of the center console	Instruction Ref. Pg. 3 Step 2 Fig. 1	Ensure that the LED harness wire is not pinched
	Move the front seats forward. Reinstall the two screws removed from the side of the center console.	Instruction Ref. Pg. 5 Step 11 Fig. 1	Do not over torque the screw.
	Reinstall the two upper screws used to secure the center console bin bezel.	Instruction Ref.  Pg. 6 Step 14 Fig. 1	Do not over torque the screws.



## Reassembly Sheet ( Expansion Kit )

Item in Question		Visual Review
 Install the trim bezel pieces onto the rear console that were originally removed	Instruction Ref. Pg. 6 Step 13 Fig. 2	Start at the top ensuring that the trim panels fully lock onto the upper edge. Be careful to not damage the component when reinstalling the trim panels onto the rear console. Fix the carpet floor mat before moving forward.
 Reinstall the original screw onto the side of the center console forward end on the drivers side of the vehicle.	Instruction Ref. Pg. 3 Step 1 Fig. 2	Do not over torque the screw.
 Reinstall the drivers foot well inner kick panel. Ensure the panel locks onto the forward clip. Lock panel to forward end of the center console	Instruction Ref. Pg. 3 Step 1 Fig. 1	Ensure that the LED harness wire is not pinched
 Reinstall the negative battery cable onto the battery lead. Tighten normally. Ensure no tools are in the engine compartment and close the hood	Instruction Ref. Pg. 3 Step 1 None	Make sure the cables are secure.
	Instruction Ref.	
	Instruction Ref.	
	Instruction Ref.	
	Instruction Ref.	
	Instruction Ref.	
	Instruction Ref.	
	Instruction Ref.	
	Instruction Ref.	
	Instruction Ref.	
	Instruction Ref.	
	Instruction Ref.	

# KMA Genuine Approved Accessories (Function Check)

	Items To Be Checked	Results of the Check
	Ensure that the ignition key is in the "OFF" position	Key is removed from the ignition switch
	Close the doors including the rear hatch	Doors closed
	Temporarily place the negative cable onto the battery lead.	Vehicle systems are active.
	Open each of the four doors (Drivers, Passenger, and two rear door one at a time	LED's installed illuminate a soft white light.
	Close doors	LED's turn "OFF" in conjunction with the dome light circuit.
	Close doors and activate the alarm system using the key fob.	LED's turn "OFF" in conjunction with the dome light circuit.
	Using the key fob, de-activate the alarm system.	White light is emitted from the LED's
	With all the doors closed, place key in the ignition and turn to the ACC position. Turn on the headlights and press the system button.	Color light emits from the LED's.
	Continue to press the system	The lights alternate color and go to the "OFF" position.
	Turn "OFF" the headlights and cycle the ignition switch to the "OFF" position	The color lights turn "OFF"
	Remove the negative lead from the battery and place so it does not come into contact with the battery terminal.	End of function test. Return the installation section and complete the remainder of the installation steps.

**TROUBLE SHOOTING**

**COLOR LIGHTING SECTION**

- PREP** - WHITE LIGHTING MUST BE IN WORKING ORDER  
 BEFORE CHECK OF COLOR LIGHTING CAN BEGIN  
 - ALL DOORS MUST BE CLOSED  
 - SIT IN DRIVER'S SEAT  
 - TURN ON IGNITION TO ACCESSORY POSITION

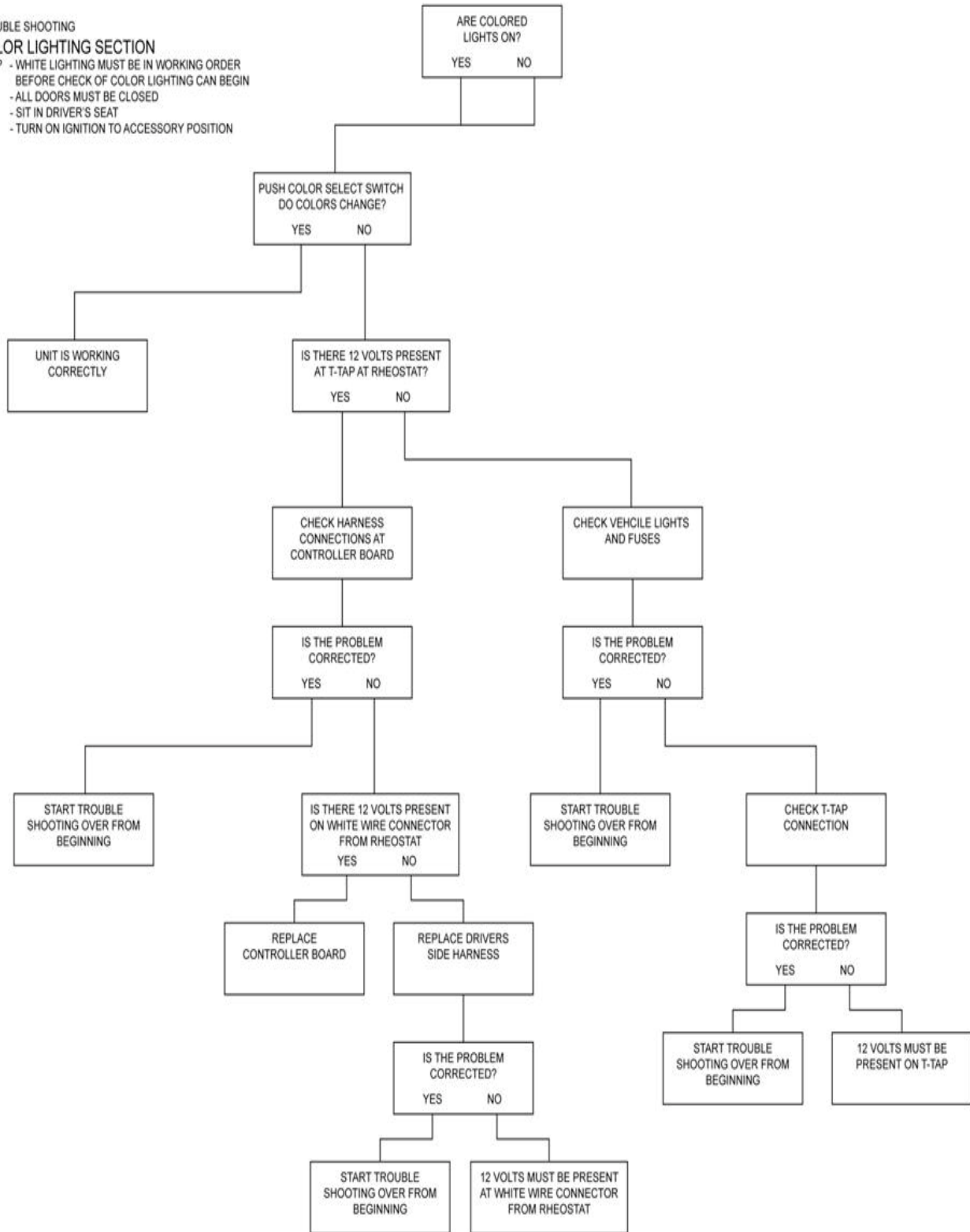

**TROUBLE SHOOTING**  
**WHITE LIGHTING SECTION**  
**PREP** - ALL DOORS MUST BE CLOSED  
 - CONNECT BATTERY  
 - WAIT 2 MINUTES  
 - TURN ON IGNITION TO ACCESSORY POSITION

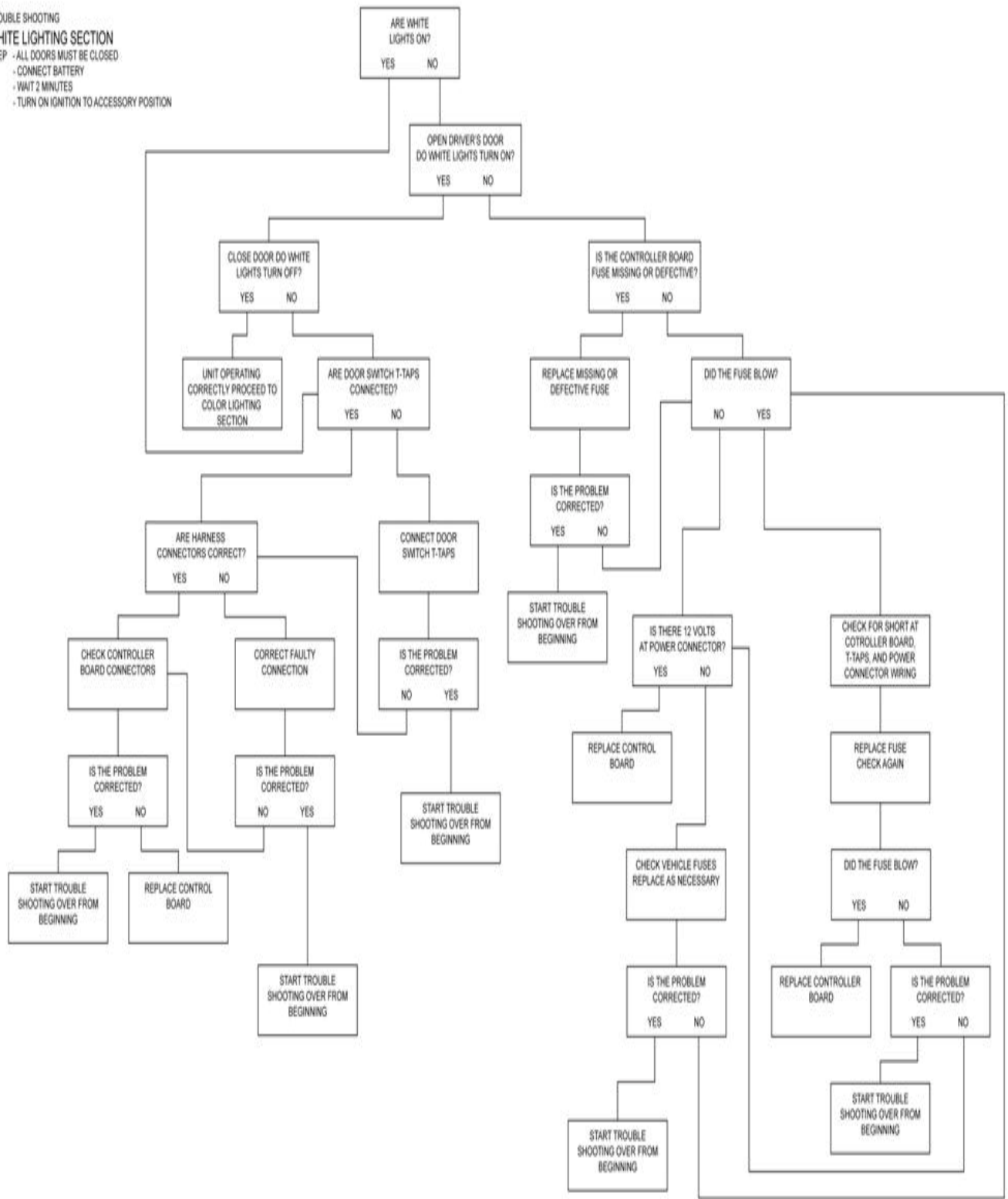

# MY 09 KIA BORREGO INTERIOR ILLUMINATION INSTALLATION TEMPLATES

## UPGRADE

 Cut out using scissors

